

Designed for Zvezda model kit #7012

Boeing 777-300ER

Technical stenciling and paint masks only

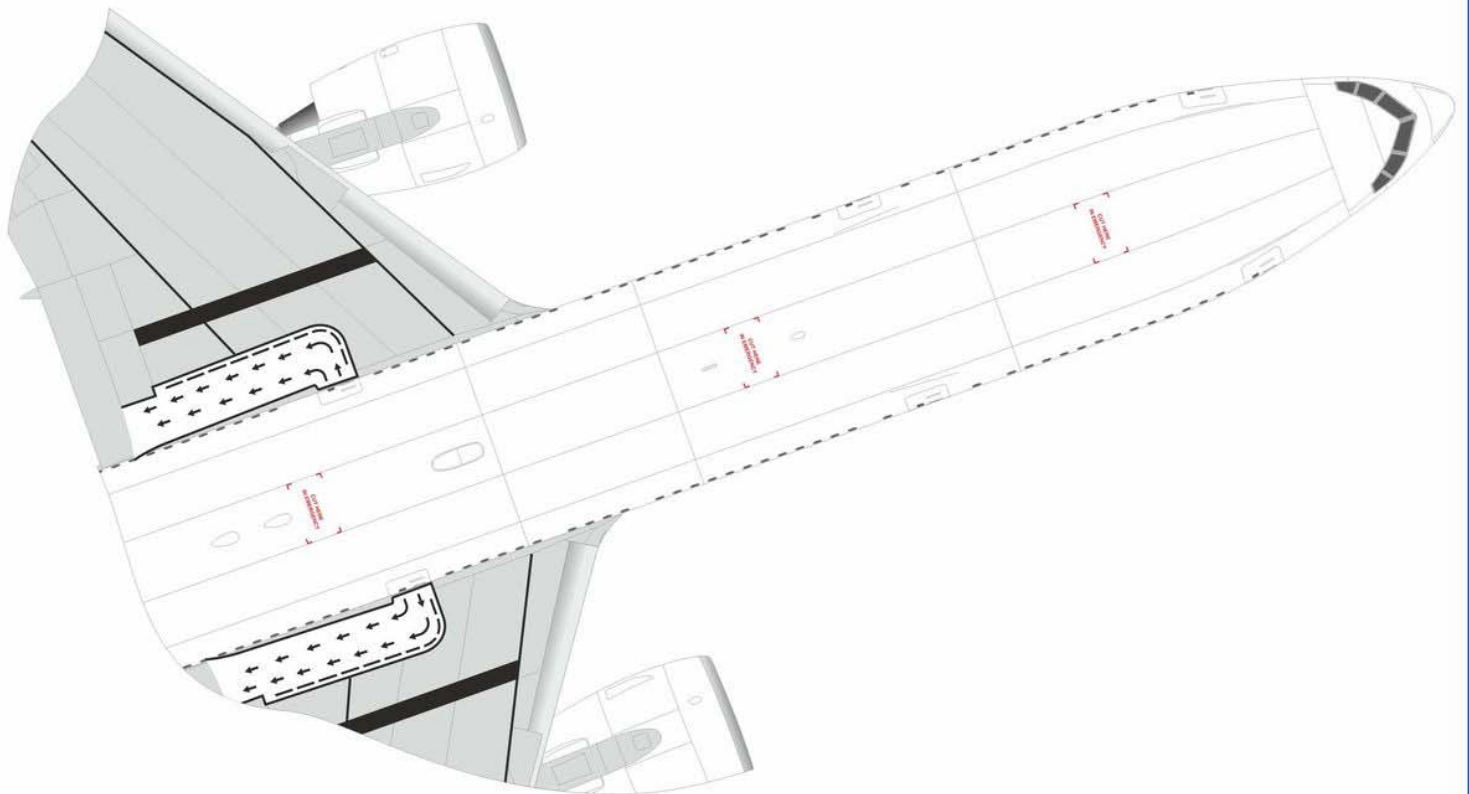
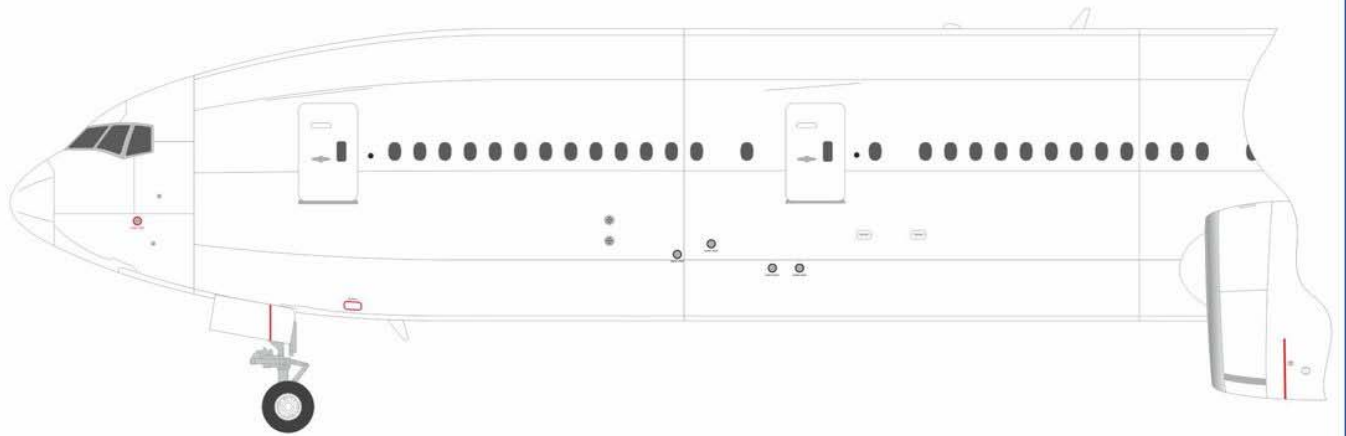

Decal Design, Logo and Cover Design is a property of AviaDecals and its affiliates.

Decal set for Boeing 777-300ER model in 1/144 scale. Designed for Zvezda model kit #7012

This decals set contains **main visible*** technical stenciling elements only and paint masks. You can download this printable manual (PDF file, A4 size) at www.aviadecals.com.

Content of this decal set:

1. Silk Screen printed decals - 1 sheet
2. Vinyl pre-cut paint masks - 1 pcs.
3. This Manual - 1 pcs.

PAINT MASKS USAGE SCHEME

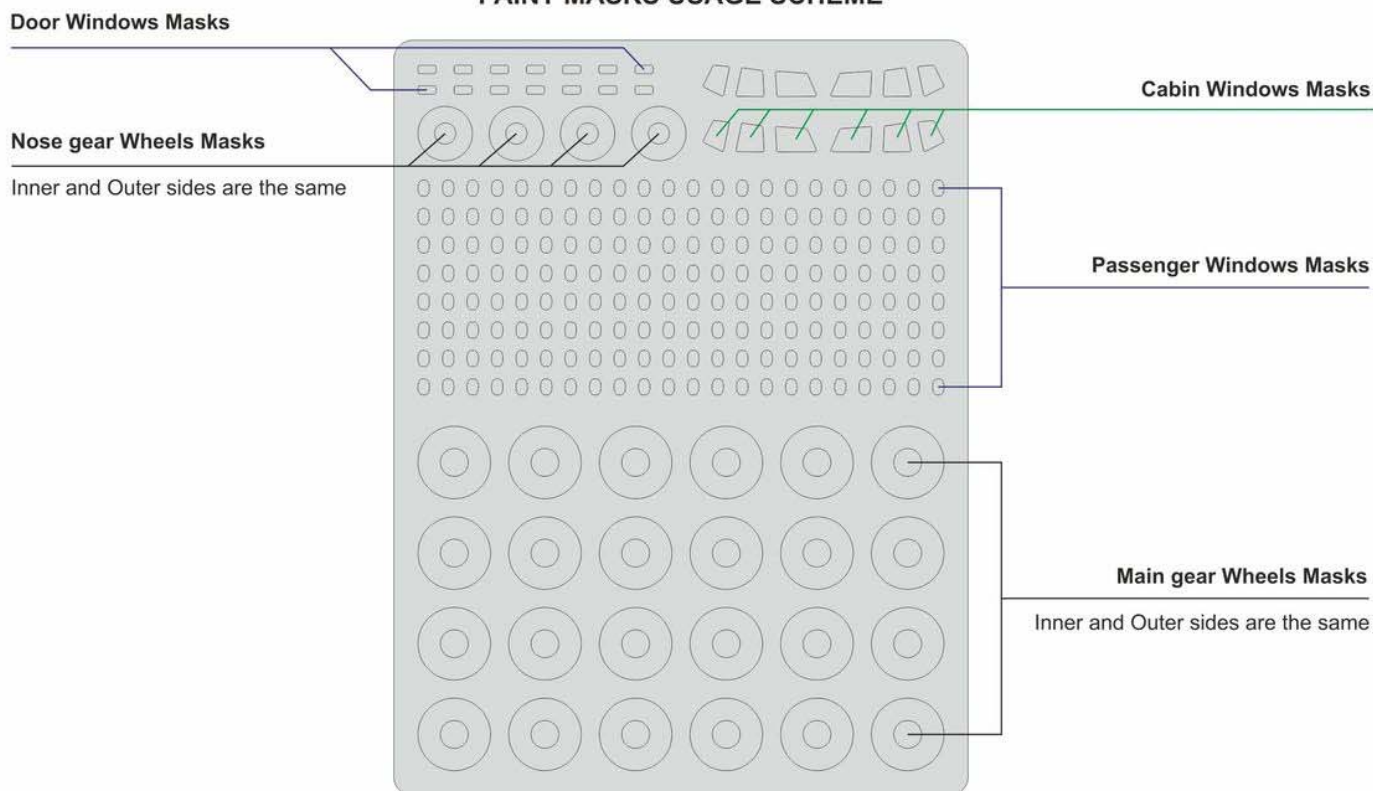

*** - Technical Stenciling note:**

This decal set contains only **main visible** (the biggest in 144 scale) elements. Real aircraft have a lot of different technical inscriptions and markings. But most of them are too small and can't be correctly reproduced in 144 scale. Thank you for your attention.

Engine cone spiral markings

Left engine is shown, right one is the same

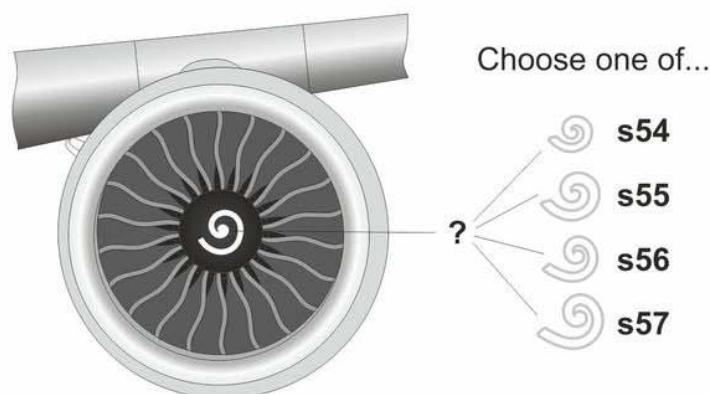

Technical Stenciling

NOTE: The arrow mark “←” near window frames indicate direction to nose.
You can cut-off unnecessary window frames.

